

SF145B

AQUAELITE

Contenuto della confezione / Package contents / Contenu de l'emballage

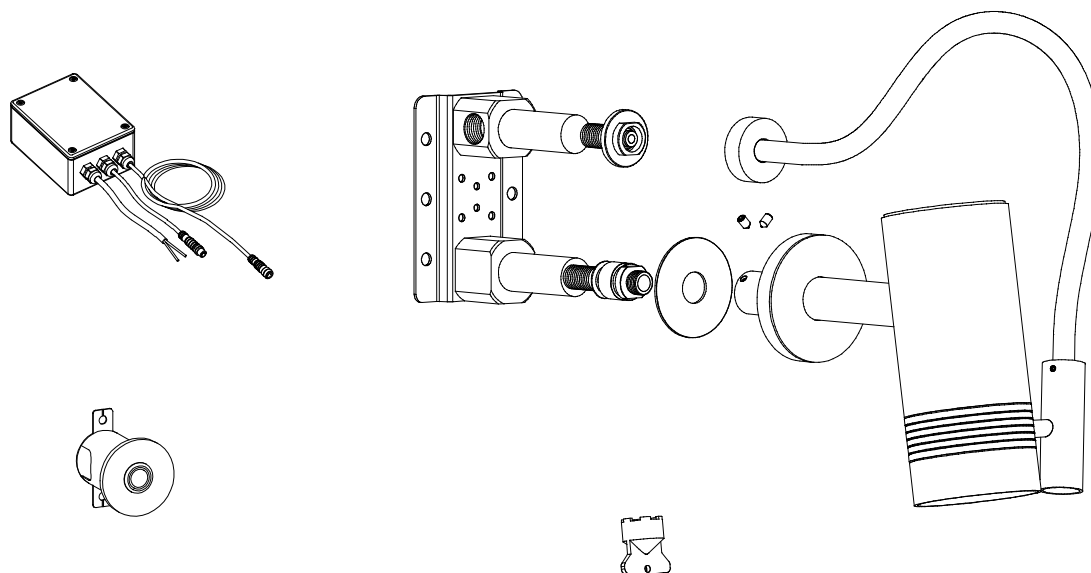

Utensili necessari / Tools needed / Outils nécessaires



Teflon



3 mm.



Indossare guanti di protezione
Wear protective gloves
Utiliser des gants isolants de protection



CH. 22 mm.
CH. 19 mm.

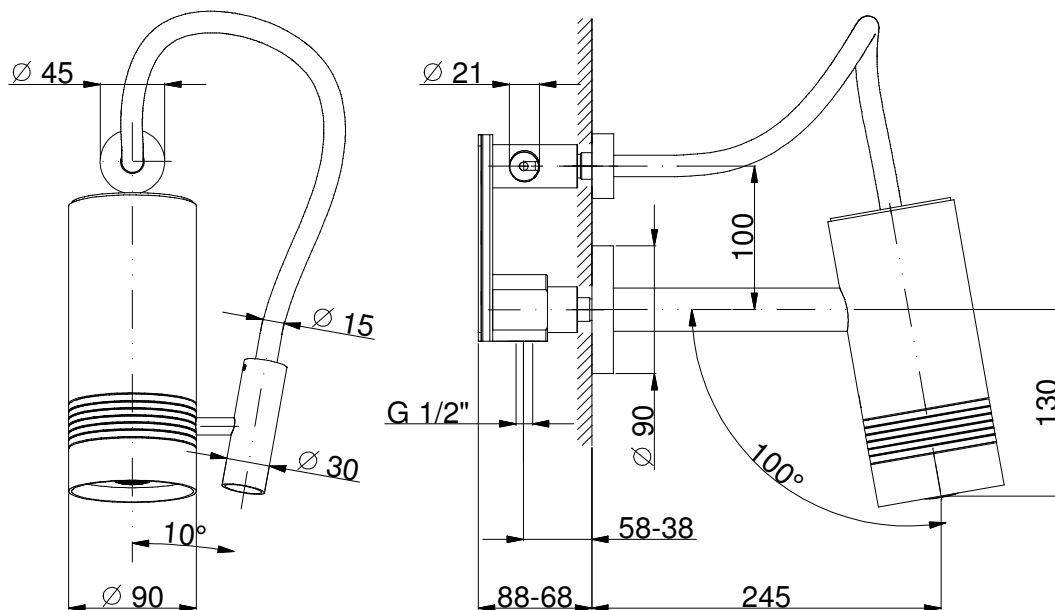

Collegamento elettrico / Electrical connection / Branchement électrique

PRESA ACQUA
WATER FEED
SORTIE EAU

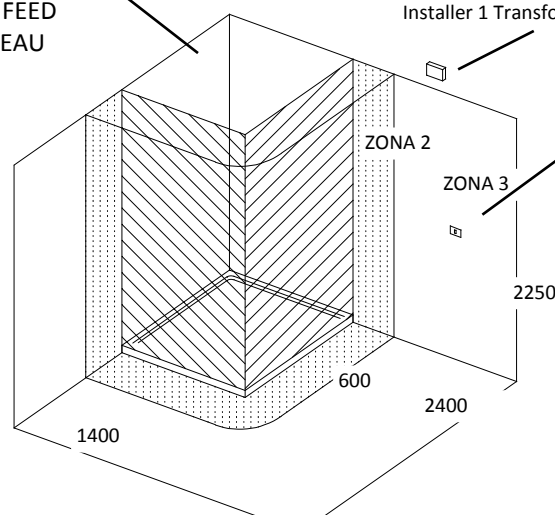

Posizionare 1 Trasformatore all'esterno della zona 2 (nella zona 3)
Place the current transformer outside area 2 (inside area 3)
Installer 1 Transformateur à l'extérieur de la zone 2 (dans la zone 3)

interruttore per alimentazione.
Non in dotazione.
Light ON/OFF switch. Not
provided.
Interrupteur pour alimentation.
Non fourni.

Per tutte le versioni dei soffioni è necessaria l'installazione di un interruttore ON/OFF sull'alimentazione del trasformatore.
All false ceiling shower heads require installation of control key for switch on/off lights on transformer power supply.
Pour toutes les versions de plafonds de douche à encastrer à faux-plafond il faut installer un interrupteur marche/arrêt sur l'alimentation du transformateur qui vient fourni avec le produit.

All'interno delle zone ZONA 0 - ZONA 1 - ZONA 2 NON DEVE ESSERE MAI PRESENTE LA TENSIONE 220V
ELECTRICAL CURRENT AT 220 V MUST NEVER BE PRESENT within areas 0 - 1 - and 2
Dans les zones ZONE 0 - ZONE 1 - ZONE 2 Ne doit en aucun cas être présent la tension 220V

Collegamento elettrico / Electrical connection / Branchement électrique

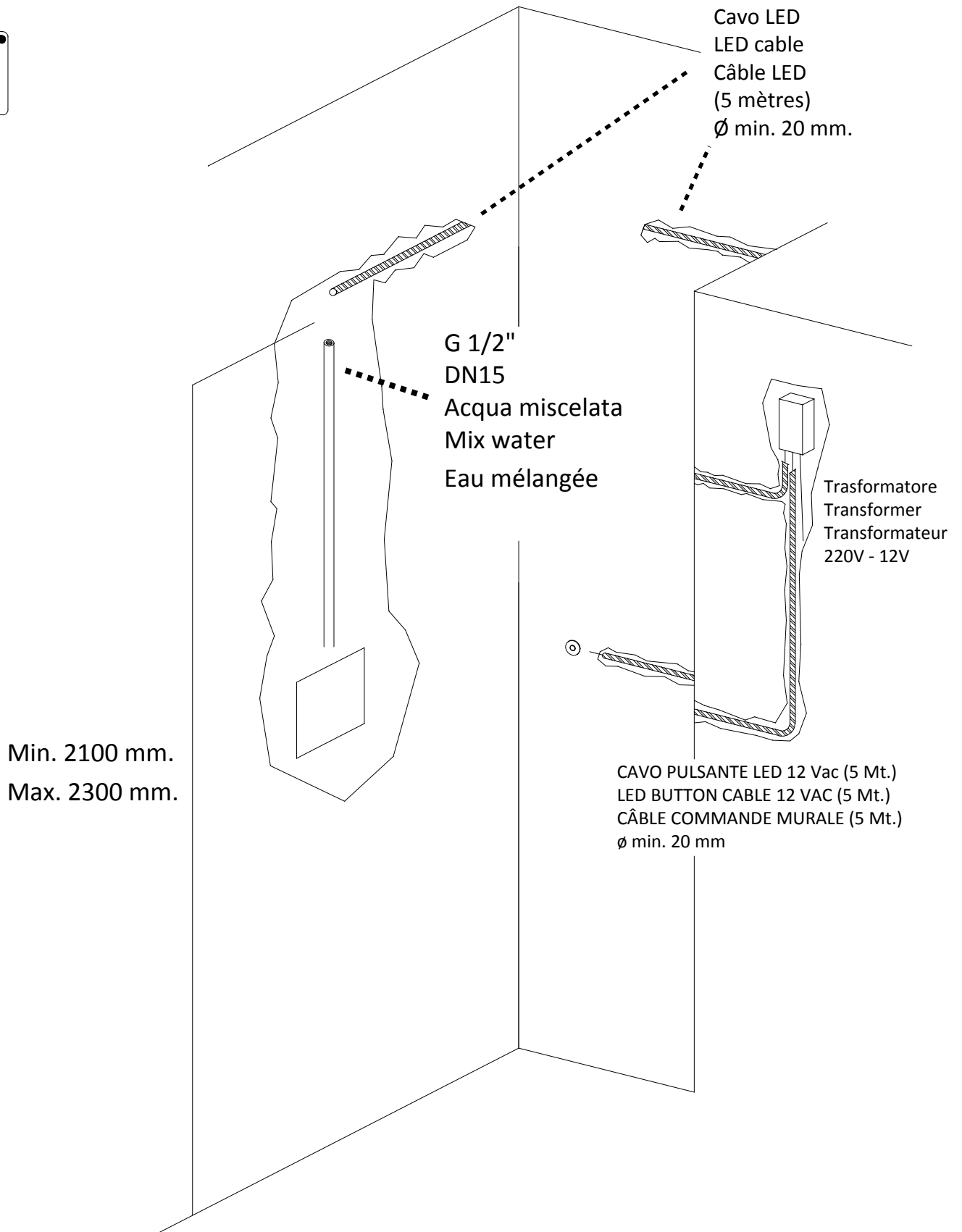
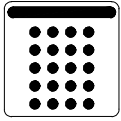

Collegamento elettrico / Electrical connection / Branchement électrique



ITA

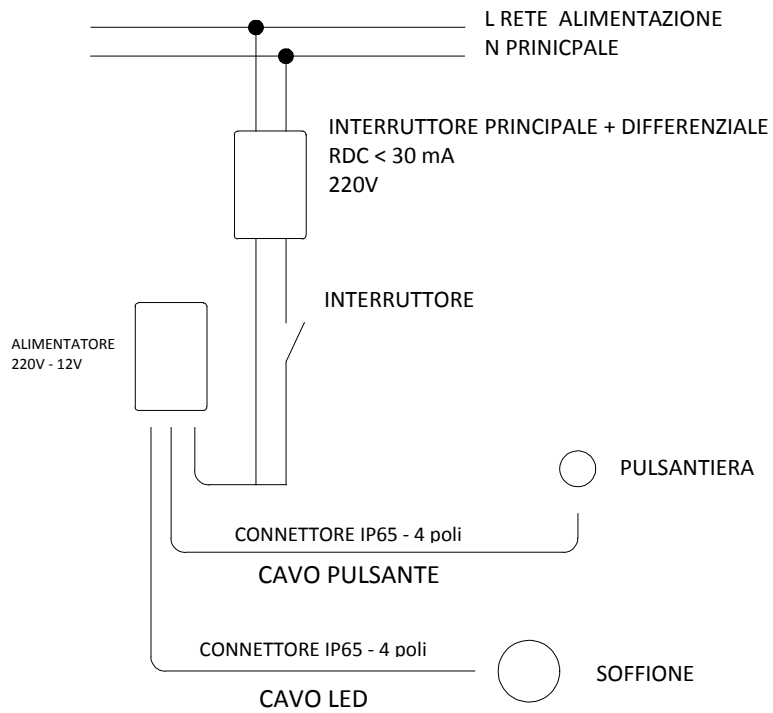

EN/FRA

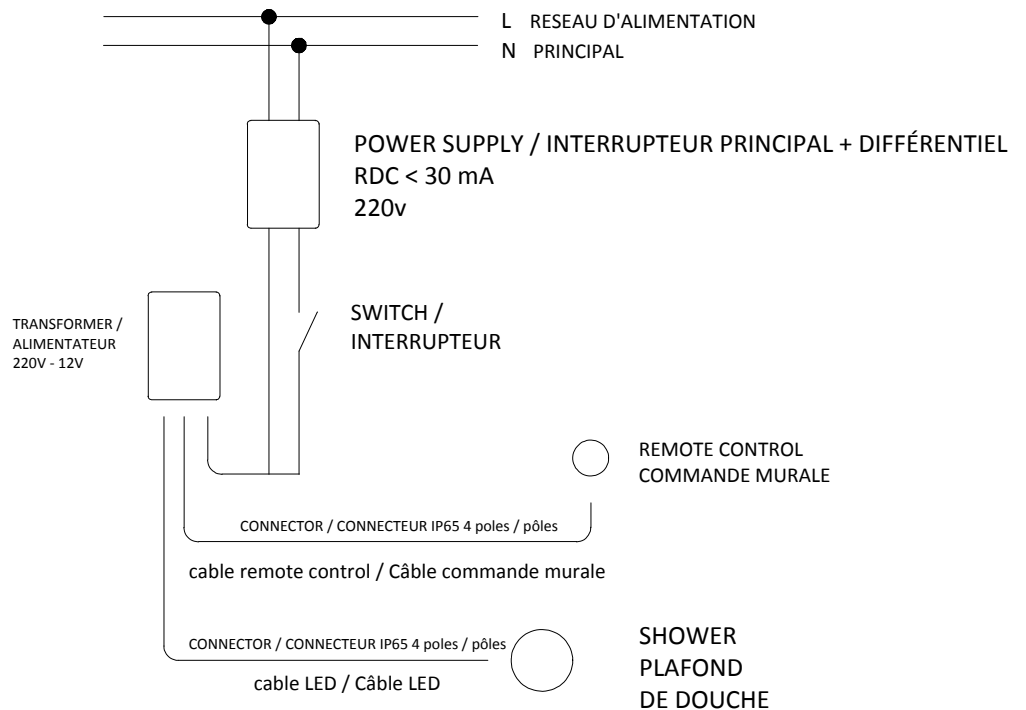

Installazione / Installations / Installation

Cavo LED
LED cable
Câble LED
(5 mètres)
Ø min. 20 mm.

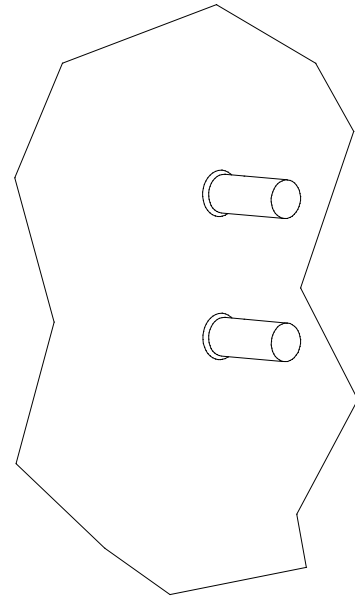
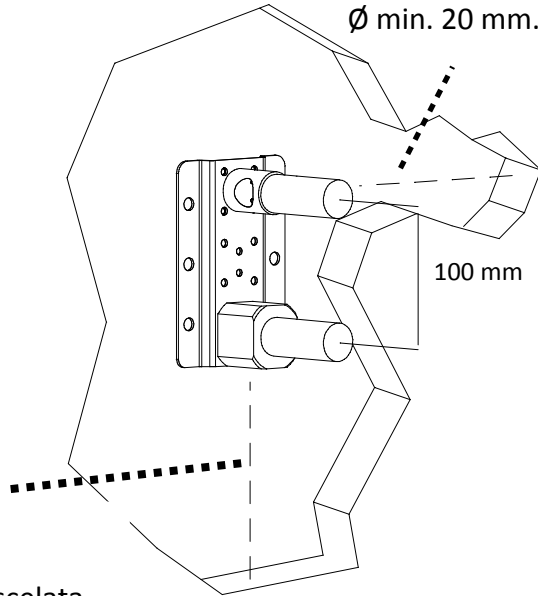

G 1/2"
DN15
Acqua miscelata
Mix water
Eau mélangée

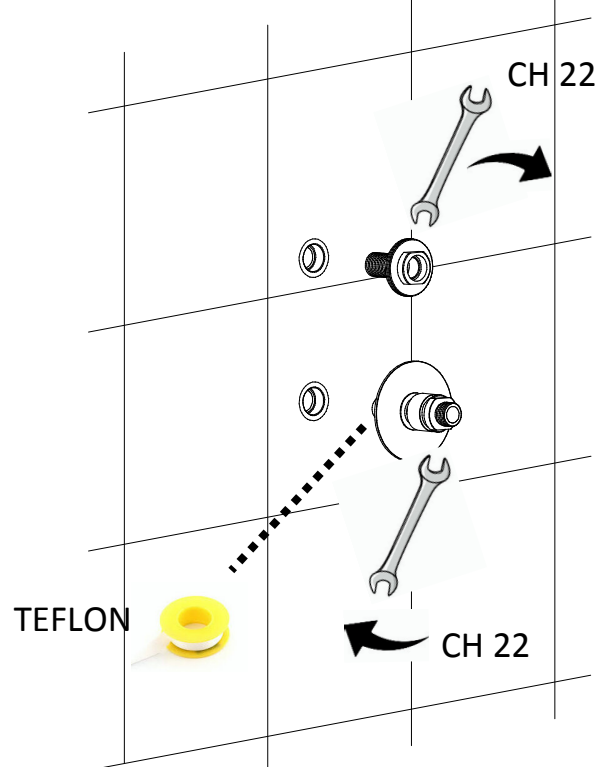
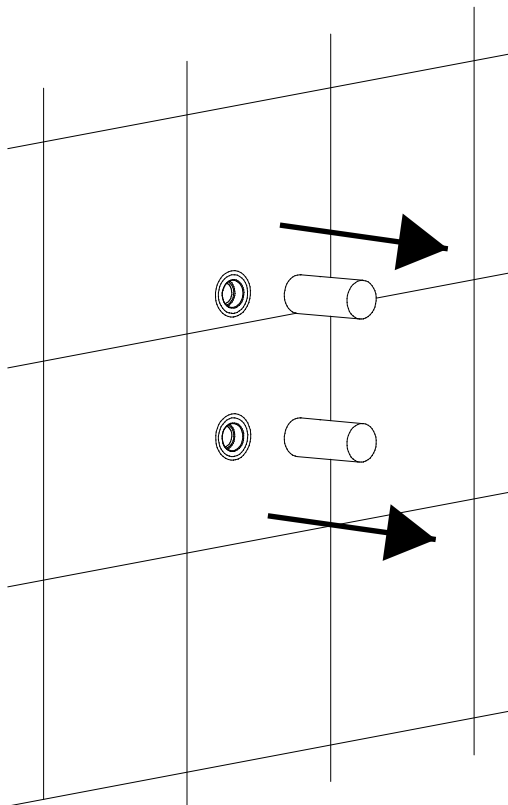

Installazione / Installations / Installation

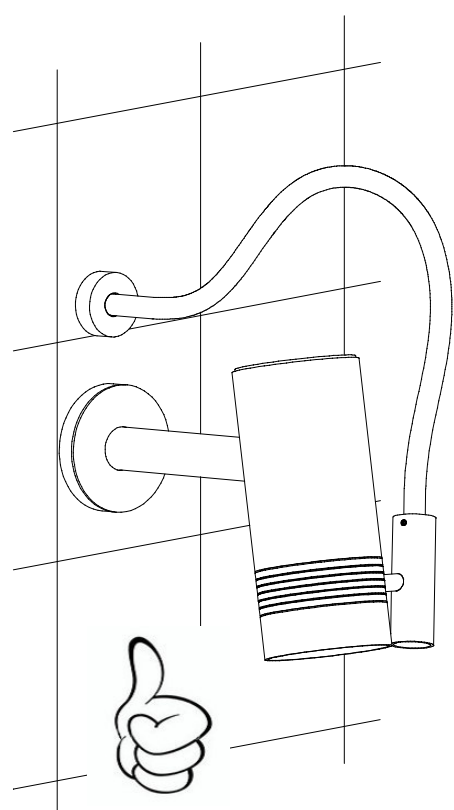
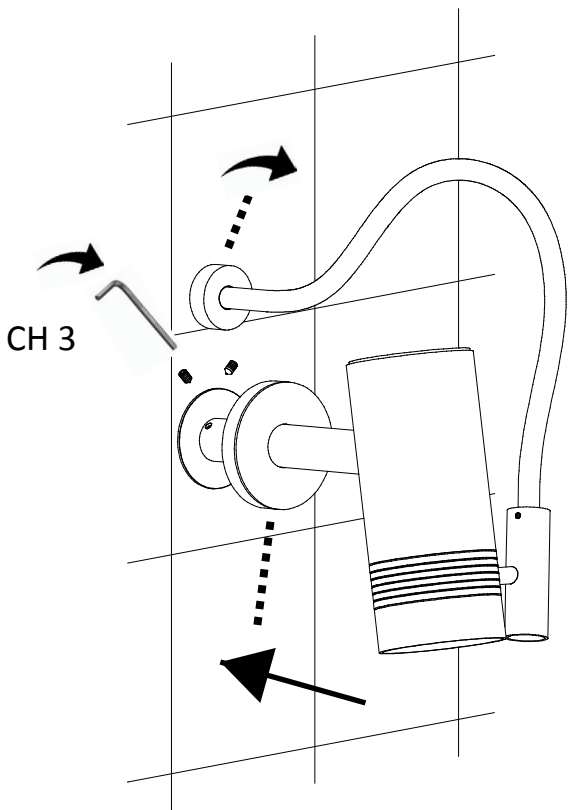
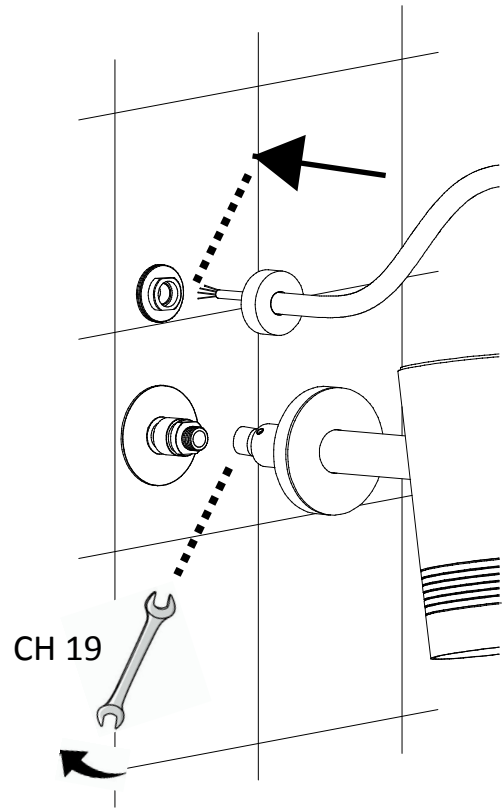
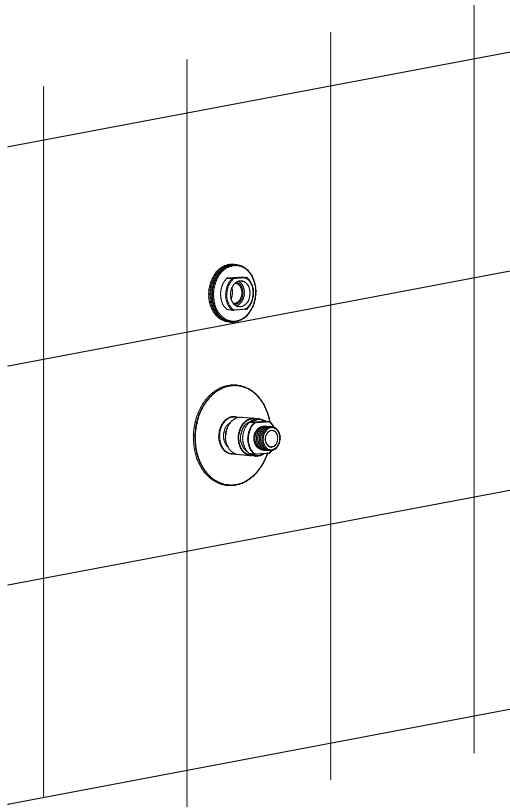

Installazione / Installations / Installation

"A"

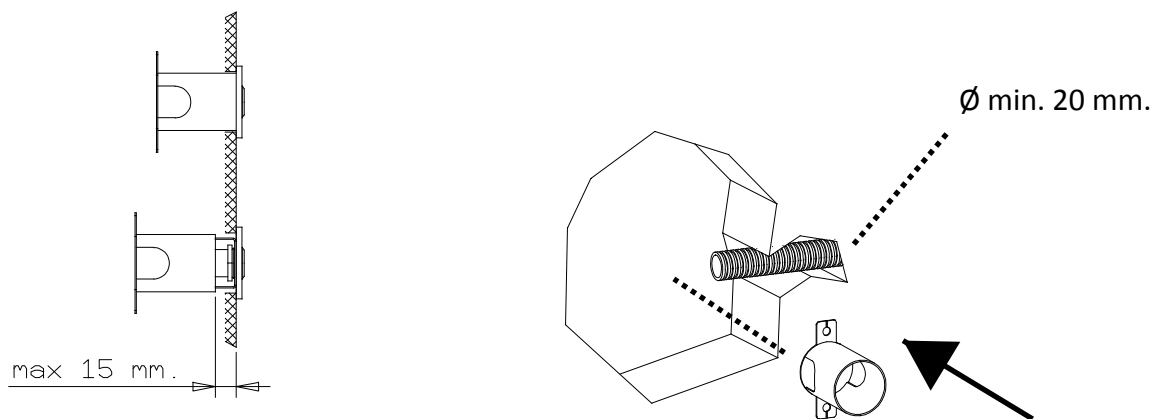

Inerire la scatola di derivazione in dotazione, facendo attenzione alla figura "A" Min. e Max.

Install concealing box make attention to min./max. deep as shown in "A" picture

Insérer la boîte de raccordement fournie avec le produit, en faisant attention à la figure "A" Min. et Max.

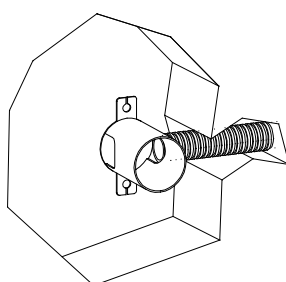

Installazione / Installations / Installation

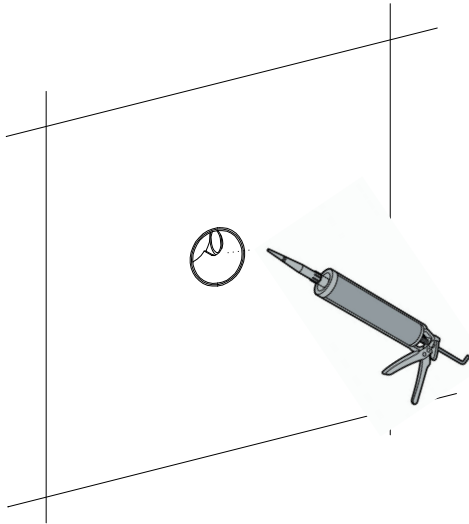

Applicare il rivestimento e siliconare il bordo della scatola di derivazione.
Install tiles and silicon the edges around the box
Poser le revêtement et mettre le silicone sur le bord de la boîte de raccordement.

Cavo LED(5 mt.)
LED CABLE (5 mt.)
Câble LED (5 mètres)

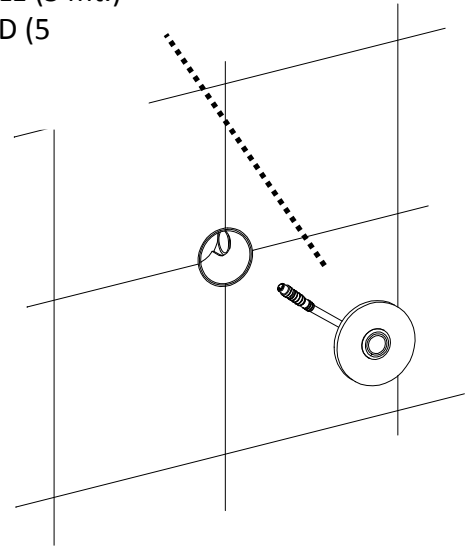

Collegare il cavo del pulsante al cavo della centralina
Siliconare il bordo posteriore della placca di copertura
Insert led cable into the sheath and silicon back part of the button before place it in position
Brancher le câble du bouton au câble de l'unité de commande.
Mettre le silicone sur le bord arrière de la plaque de finition

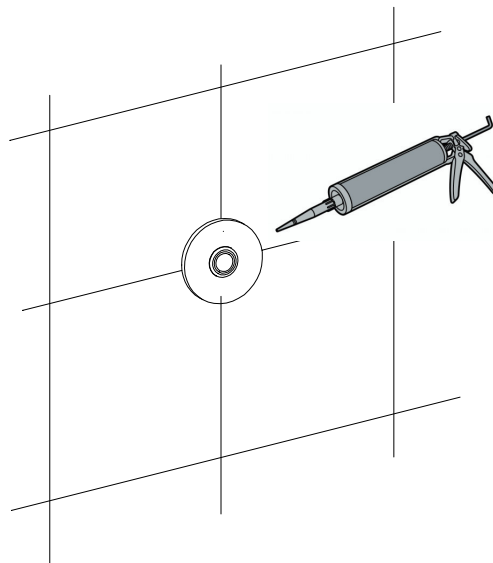

Una volta collegato il cavo del pulsante inserire la placca all'interno della scatola di derivazione e siliconare tutto il bordo esterno della stessa
Once button is in position silicon the edge to avoid leaking
Une fois branché le câble du bouton, insérer la plaque à l'intérieur de la boîte de raccordement et mettre le silicone sur tout le bord extérieur de la même.

Funzioni / Functions / Fonctions

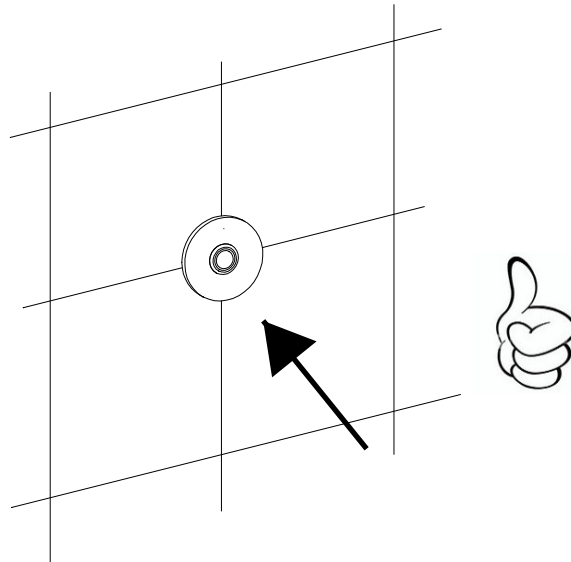

Push/Appuyer

1 = on luci
1 = off luci

1+1 = Bianco
1+1 = Verde
1+1 = Azzurro
1+1 = Blu
1+1 = Viola
1+1 = Rosso
1+1 = Giallo

5" = ciclo automatico

1 = on luci
1 = off luci

1+1 = White
1+1 = Green
1+1 = Light Blu
1+1 = Blu
1+1 = Violet
1+1 = Red
1+1 = Yellow

5" = Automatic loop

1 = marche lumières
1 = arrêt lumières

1+1 = Blanc
1+1 = Vert
1+1 = Azur
1+1 = Bleu
1+1 = Violet
1+1 = Rouge
1+1 = Jaune

5" = Cycle automatique

Manutenzione / Maintenance / Entretien

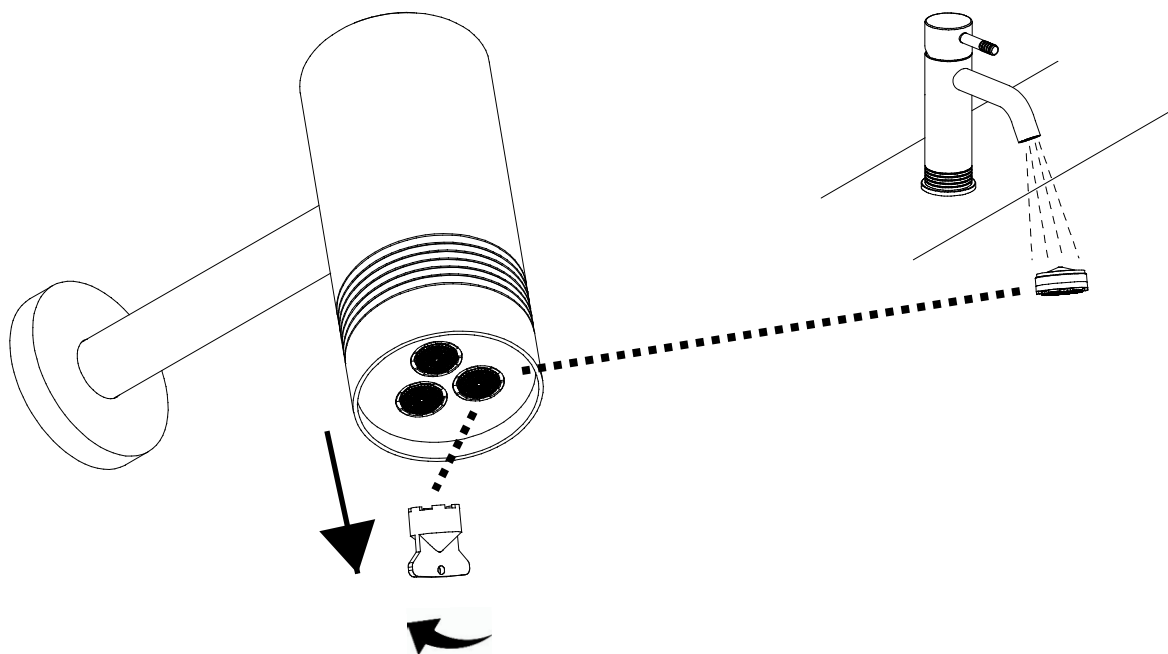

AQUAelite / ANPA s.r.l.

Viale dello sport, 16/18 2106 Gavirate VA Italy

T.+39 0332 732906 | F. +39 0332 735819 | www.aquaelite.it | info@aquaelite.it

AQUAELITE
